

ZONE	REV	DESCRIPTION	ECN	DATE	CHK	APP
	00	RELEASE	NL04-1379	8-19	RRM	RWD WTM
	01	ADD BOX-11 FRT UNIT & LOW VOLT BOX TU	-	-	-	-
	01	IT.2 P/N WAS 425-1729; IT.3 WAS 422-6373	-	-	-	-
	01	DEL. IT.4 CABLE TEE; IT. 6 WAS 424-5259	-	-	-	-
	01	DEL. 422-6482 20-INCH CABLE	NL06-1306	4-12	FL	RWD WTM
	02	RECORD UPDATE L950 #8UP; MDL #12 & 13;	-	-	-	-
	02	MDL #14 & 15; DRIVE MDL 1-4 IN SR CABT NL06-1346	12-	-	FL	-

**CAN CONNECTION ORDER:**

**FROM BACK OF CAB:**  
**CAN 1:** 80 INCH CA-BAYONET FROM BACK OF CAB TO REMOTE-13;  
 80 INCH CA-BAYONET FROM REMOTE-13 TO REMOTE-12;  
 200 INCH CA-BAYONET FROM REMOTE-12 TO REMOTE-15 (ENGINE);  
 30 INCH CA-BAYONET FROM REMOTE-15 (ENGINE) TO REMOTE-14 (TRANSLATOR);  
 FROM REMOTE-14 (TRANSLATOR) TO TERMINATOR (ITEM 5)

**FROM BACK OF CAB:**  
**CAN 2:** 200 INCH CA-BAYONET FROM BACK OF CAB TO REMOTE-10;  
 30 INCH CA-BAYONET FROM REMOTE-10 TO REMOTE-11;  
 FROM REMOTE-11 TO TERMINATOR (ITEM 5)

**FROM BACK OF CAB:**  
**CAN 3:** 200 INCH CA-BAYONET FROM BACK OF CAB TO DRIVE MDL-4 (DRIVE MDL #1-4 IN SR CONV BOX);  
 30 INCH CA-BAYONET (ITEM 6) FROM DRIVE MDL-4 TO DRIVE MDL-3;  
 30 INCH CA-BAYONET (ITEM 6) FROM DRIVE MDL-3 TO DRIVE MDL-2;  
 30 INCH CA-BAYONET (ITEM 6) FROM DRIVE MDL-2 TO DRIVE MDL-1;  
 FROM REMOTE-1 TO TERMINATOR (ITEM 5).

**NOTE:**  
PARTS LIST FOR REFERENCE ONLY

ITEM	PART NO.	QTY	DESCRIPTION
11	425-1675	REF	ASSEMBLY LOW VOLTAGE BOX
10	425-8835	REF	DATA CABLE 300 INCH CA-BAYONET
9	425-0884	REF	DATA CABLE 400 INCH CA-BAYONET
8	425-0882	REF	DATA CABLE 200 INCH CA-BAYONET
7	425-0883	REF	DATA CABLE 80 INCH CA-BAYONET
6	425-5843	REF	DATA CABLE 30 INCH CA-BAYONET
5	422-6487	REF	DATA CABLE TERMINATOR CA-BAYONET
4	-	-	-
3	425-5725	REF	ASSEMBLY TRANSLATOR
2	424-7179	REF	ASSEMBLY DRIVE MODULE
1	424-5246	REF	ASSEMBLY REMOTE MODULE

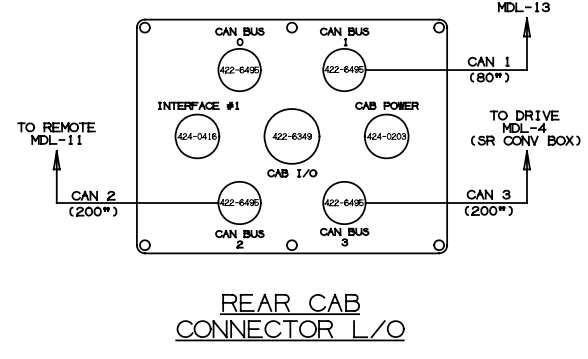
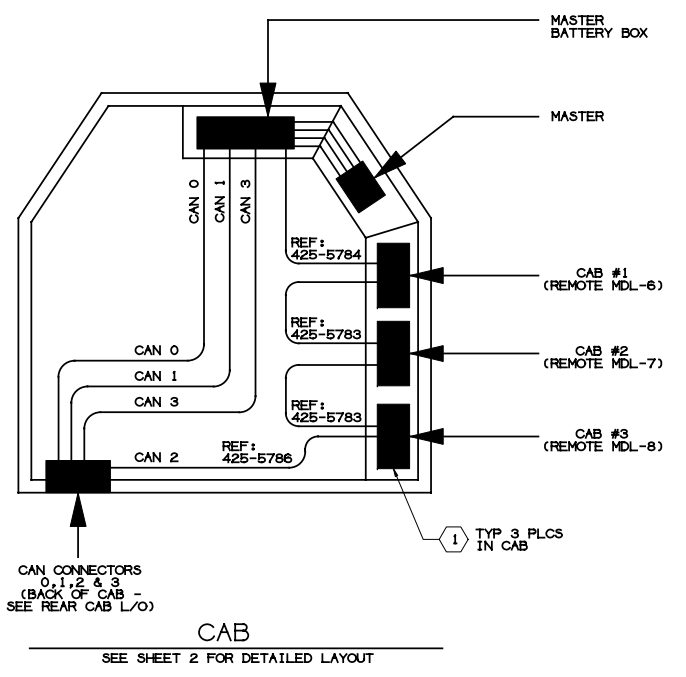

THIS DRAWING AND ALL DATA THEREIN IS THE PROPERTY OF LETOURNEAU, INC. IT IS CONFIDENTIAL AND MUST NOT BE COPIED, IT IS LOANED SUBJECT TO RETURN UPON DEMAND AND IS NOT TO BE USED IN ANY WAY DETRIMENTAL TO OUR INTEREST. INTERPRET DIM & TOL PER LETOURNEAU SPEC 1850.00.

UNLESS OTHERWISE SPECIFIED:  
 \*DIMENSIONS ARE IN INCHES & APPLY BEFORE PLATING OR FINISH COATINGS.  
 \*TOLERANCES ON ANGLES: 41° FRACTIONS 41/16 .XX DECIMAL .03 .XXX DECIMAL .015  
 \*MACHINED CORNERS: 1/64 X 45°  
 \*WELD PROPERTIES SHALL MEET THE MINIMUM REQUIREMENTS OF THE BASE MATERIAL.  
 THIRD ANGLE PROJECTION

425-4432

LeTourneau, Inc.  
CAN CONN CABLE LAYOUT  
L950 #2 & UP  
D950 #4 & UP  
DO NOT SCALE 4254431 02

DATE: 1/11 11:57

REVISIONS		ECN	DATE	CHK	APP
00	RELEASE	NL04-1379	8-19	RFM	RWD WTM
01	NO CHANGE THIS SHEET	NL06-1305	4-12	FL	RWD WTM
02	NO CHANGE THIS SHEET	NL06-1345	12-	FL	RWD WTM

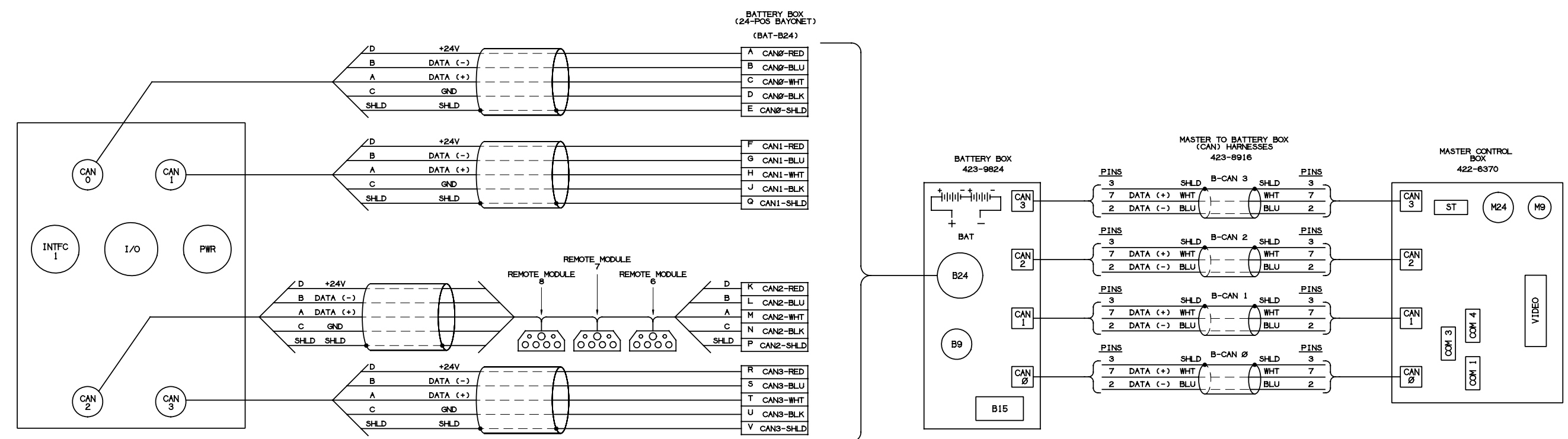

CAB CONNECTORS

BATTERY BOX SOCKET CONNECTOR (BAT-B15)	DESTINATION	(PINS)
1 DIG24-DR	M24	N
2 DIG24-FB	M24	P
3 IVO24-DR	M24	L
4 IVO24-FB	M24	M
5 IVO PWR	0601-PWR	F
6 IVO GND	0601-RET	B
7 IVO PWR	0701-PWR	F
8 IVO GND	0701-RET	B
9 IVO PWR	0801-PWR	F
10 IVO GND	0801-RET	B
11 A/C-PWR	A/C-36	4
12		
13		
14 COOL-PWR		
15 COOL-GND		

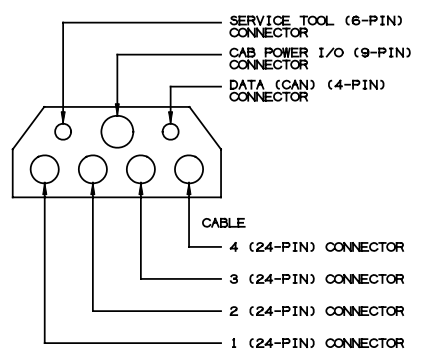

REMOTE MODULE CONNECTOR DIAGRAM

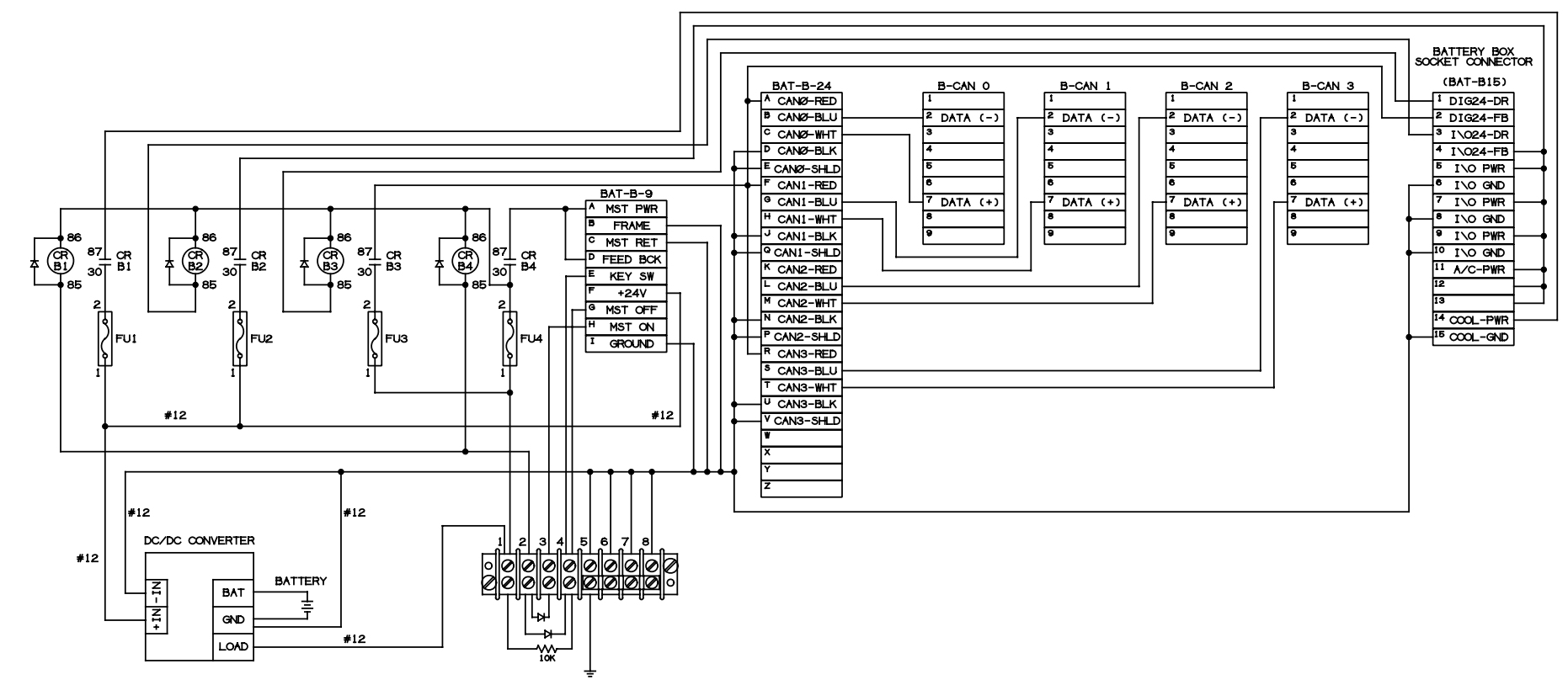

MASTER BATTERY BOX WIRING SCHEMATIC